

HYUNDAI
POWER PRODUCTS

SCARIFIER HYSC1532E

Instruction Manual



GENUINE PRODUCT OF
HYUNDAI CORPORATION

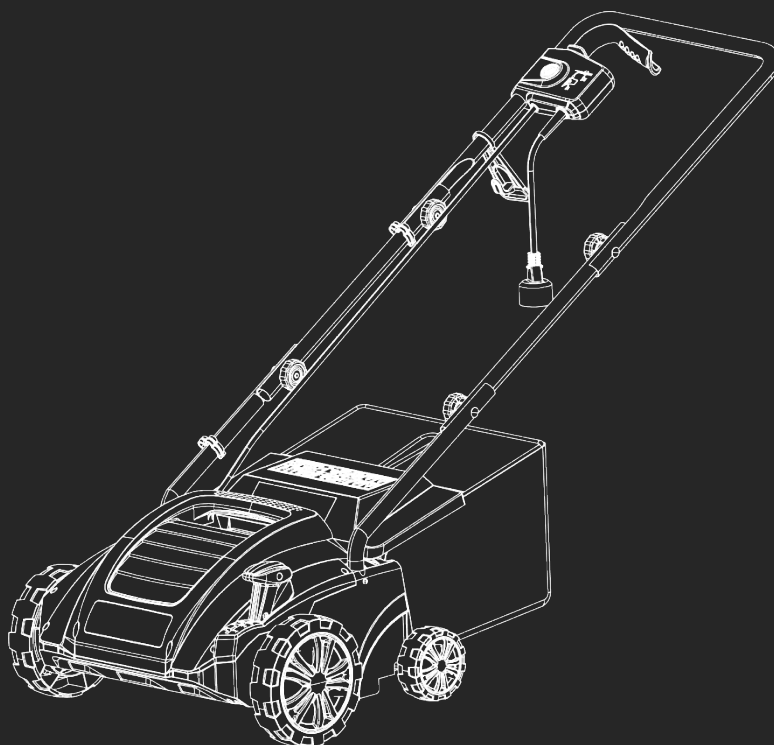

WARNING: Read the instructions carefully before use.

Iss:Oct/25

Contents

Introduction.....	3	Recycling And Disposal.....	47
Safety Information.....	4-14	Declaration Of Conformity.....	48
Understand Your Machine.....	4	Useful Information.....	49
Personal Safety.....	4-5	Our YouTube Channel.....	49
Inspect Your Machine.....	5-6	Warranty.....	49
Work Area.....	6	Manual Updates.....	49
During Use.....	7	Returning Your Product.....	49
Electricity.....	9	Leaving A Review.....	49
Double Insulated Devices.....	9	Ordering Spare Parts.....	49
Vibrations.....	10	Product Record.....	50
Noise.....	10	Contact Us.....	51
Residual Risks.....	10		
Intended Use.....	11		
Personal Protective Equipment.....	12		
Symbols On The Machine.....	13-14		
Unboxing.....	15		
In The Box.....	16-17		
Features.....	18-19		
Assembly.....	20-28		
Lower Handles.....	20-22		
Upper Handle & Switch Module.....	23-24		
Cable Management.....	25		
Collection Box Assembly.....	26		
Attaching Collection Box.....	27-28		
Operation.....	29-33		
Understanding Scarification.....	29		
Scarifying & Raking.....	30		
Before Each Use.....	31		
Height Adjustment.....	32		
Starting & Stopping.....	33		
Maintenance & Care.....	34-36		
Changing The Cartridge.....	34		
General Maintenance.....	35		
Transportation.....	35		
Storage.....	35		
Cleaning.....	36		
The Blade.....	36		
Spare Parts.....	37-45		
Specifications.....	46		

Introduction

Thank You For Purchasing Your HYUNDAI Product

We work very hard to give all of our customers the best possible service. If you have any problems, before leaving negative feedback, please contact us to give us a chance to resolve the issue. We would be delighted if you left us positive feedback! Thank you for purchasing this product.

Important!



WARNING: READ THE INSTRUCTION BOOKLET THOROUGHLY BEFORE USING THE MACHINE. Keep for future reference and pass it on if the machine is loaned or sold to another user.

This manual has been produced by Hyundai Power Products and should be kept with the product. Please read and understand these instructions before you use your product. Failure to do this may result in personal injury or damage to the product.

The safety precautions and warnings are to ensure your safety and protect you from harm or damage to the product.

The information contained in this manual was accurate at the time of production, however HYUNDAI Power Products may make modifications to the product without notification.

Safety Information

Understand Your Machine

- **WARNING!** You must read these instructions carefully before operating the machine. Make sure that you are familiar with the controls and properly operate the machine. You must learn how to stop the machine quickly. If you do not follow the warnings and instructions, it may result in fire and/or serious injury. Make sure to save all warnings and instructions for future reference.
- Read this manual and labels affixed to the machine to understand its limitations and potential hazards.
- Be thoroughly familiar with the controls and their proper operation. Know how to stop the machine and disengage the controls quickly.
- If the unit is to be used by someone other than original purchaser, or is to be loaned, rented, or sold, always provide this manual and any needed safety training before operation. The user can prevent and is responsible for accidents or injuries that may occur to themselves, to other people, or to property.
- Do not force the machine beyond its limits. Use the correct machine for your application.
- Know how to stop the machine quickly in case of emergency. Understand the use of all controls.
- ALL MAINTENANCE other than that listed in this manual, should be carried out by professionally trained and certified personnel.
- When using this machine for the first time and before actual work, you **MUST** learn how to handle the machine from an experienced or skilled person.

Personal Safety

- **WARNING!** Never allow children or people unfamiliar with these instructions to use the product. Local regulations can restrict the minimum age of the operator.
- Keep children, pets, and other people not using the unit away from the work area (at least 15m). Be alert and shut off the unit if anyone enters work area. Keep children under the watchful care of a responsible adult.
- Stay alert, watch what you are doing and use common sense when operating the machine. Never operate the machine when unwell or tired, or if you have taken alcohol, medicine, drugs or any substances which may slow your reflexes and compromise judgment. A moment of inattention while operating the machine may result in serious personal injury.
- Appropriate Personal Protective Equipment (PPE), **MUST** be worn at all times when operating or repairing the machine. Always wear anti-slip and resistant work footwear and long trousers while using the machine. Do not use the machine when barefoot, wearing sandals or similar lightweight footwear. Do not wear chains, bracelets or clothing that is loose fitting or hanging ties or cords. Tie long hair back. Always wear protective earplugs. Loose clothes, jewellery, or long hair can be caught in moving parts. Protect eyes, face, and head from objects that may be thrown from the unit. Always wear safety goggles or safety glasses with side shields when operating.
- Always keep hands and feet away from all moving parts during operation. Moving parts can cut or crush body parts. Always keep hands and feet away from all pinch points.

Safety Information

Personal Safety (Continued)

- Do not touch parts that might be hot from operation. Allow parts to cool before attempting to maintain, adjust, or service.
- Do not overreach. Keep proper footing and balance at all times. This enables better control of the machine in unexpected situations. Extending your body too far can result in a loss of balance and you may fall which will result in injury.
- Never place any part of your body where it would be in danger if movement should occur during assembly, installation, and operation, maintenance, repairing or moving.
- Keep in mind that the operator or user is responsible for accidents, hazards or unexpected events involving the machine that occur to other people or their property. It is the responsibility of the user to assess the potential risk of the area where work is being carried out. The operator or user must take all necessary precautions to ensure their own safety and that of others, especially on slopes or rough, slippery and unstable ground.

Inspect Your Machine

- Check your machine before starting it. Keep guards in place and in working order. Make sure all nuts, bolts, etc., are securely tightened.
- You must check the general condition of the machine before use.
- Never operate the machine when it is in need of repair or is in poor mechanical condition. Replace damaged, missing, or failed parts before using it. Keep the machine in safe working condition.
- Do not use the machine if the machine's switch does not turn off the machine when running. Any machine that can't be controlled with the switch is dangerous and must be replaced.
- Regularly check to see that keys and adjusting wrenches are removed from the machine area before starting it. A wrench or a key that is left attached to a rotating part of the machine may result in personal injury.
- If the machine should start to vibrate abnormally, stop the machine and check immediately for the cause. Vibration is generally a warning sign of trouble.
- Avoid accidental starting. Be sure the switch is off before transporting the machine or performing any maintenance or service on the unit. Transporting or performing maintenance or service on a machine with its switch on invites accidents.
- Do not tamper with or disable safety systems.
- Only use manufacturer-recommended attachments.
- Before using, always visually inspect to see that the tools are not worn out or damaged. Replace worn out or damaged elements and bolts in set to preserve balance.
- Keep the machine in good operating condition. Operating the machine in poor or questionable condition could result in serious injury.
- Be sure all safety devices are in working order and warning labels are in place. These items are installed for your safety.

Safety Information

Work Area

- You must only work in daylight or with good artificial light in good visibility conditions. Do not work at night, at times of heavy fog, or at any other times when your field of vision might be limited and it would be difficult to gain a clear view of the area.
- Keep people, children and animals away from the working area.
- Operate on flat, level ground.
- DO NOT work on wet ground. If there has been heavy rain on the working site, wait until the ground has dried up.
- Never park the machine in a place with unstable ground which could give way.
- You must be careful near ravines, ditches or embankments.
- Never operate on gravel drives, walks, or roads.
- Do not work in the rain, when there is a thunderstorm or lightning risk, at times of strong or gale force winds, or at any other times when the weather conditions might make it unsafe to use this product. If there is bad weather conditions, do not use the machine.
- Make sure you thoroughly inspect the entire work area and remove all objects and anything that could be thrown by the machine or could damage the machine (branches, stones, wire, toys, etc). Attempting to clear the work area whilst using the machine will reduce your concentration and creates a trip hazard. Any liquid spilled on the floor may result in you slipping.
- Find and locate all fixed objects in the ground, such as sprinkler systems, poles, water valves, bases for washing lines etc. Make sure that you check for hidden electrical cables or similar on the surface of the lawn. ALWAYS run the machine around these objects. NEVER run the machine over foreign objects.
- DO NOT operate power tools in explosive atmospheres, such as in the presence of flammable liquids, gases or dust. Power tools may create sparks, which may ignite the dust or fumes.
- This machine is only for outdoor use.

Safety Information

During Use

- Do not operate the machine in confined areas where there may be a risk of crushing the operator between the machine and another object.
- Never attempt to make any adjustments, while the machine is running.
- You must unplug and switch off the machine:
 - Before checking or working on the machine.
 - When transporting the machine.
 - Whenever you leave the machine unattended.
 - If the machine starts to vibrate abnormally.
- **WARNING!** If something breaks or an accident happens whilst working, you must turn off the machine immediately and move the machine away to prevent further damage. If an accident happens with injuries or third parties are injured, carry out the first aid measures most suitable for the situation immediately and contact the medical authorities for any necessary health care. Carefully remove any debris that might cause damage or harm persons or animals should it not be seen.
- After striking a foreign object, stop the machine immediately and remove the plug from power. Inspect the machine thoroughly for damage. Repair the damage (if required) before continuing.
- Keep extension cord away from cutting elements.
- Never operate the machine with damaged guards or without the guard in place.
- Keep hands and feet away from the cutting means at all times especially when switching on the motor.

Safety Information

Electricity (Where Applicable)

DANGER : ELECTRICITY CAN KILL – NEVER WORK ON LIVE / ENERGISED EQUIPMENT.



- Prior to carrying out any maintenance work you **MUST** identify electrical isolation methods and isolate all electrical supplies.
- Prior to use and with all electrical supplies isolated, you **MUST** check all electrical cables, plugs and connectors for the following;
 - Are intact and have no signs of damage, to include but not limited to bare wires, chaffing, cuts and loose wiring.
 - If there are any signs of damage, the damaged item **MUST** be taken out of service until the damage has been repaired by an electrically competent person.
 - All trailing cables should be routed so as not to cause any kind of trip hazard.
 - **NEVER** work on or near electricity with wet hands, wet clothing and wet gloves.

Safety Information

Electricity (Continued)

- Power tools plug must match the outlet. Never modify the plug in any way. DO NOT use any adapter plugs with earthed (grounded) power tools. Unmodified plugs and matching outlets will reduce risk of electric shock.
- DO NOT expose this power tool to rain or wet conditions. Water entering a power tool will increase the risk of electric shock. DO NOT abuse the power cord. Never use the cord for carrying, pulling or unplugging the power tool. Keep the cord away from heat, oil and sharp edges or moving parts. Damaged or entangled cords increase the risk of electric shock. When operating a power tool, use an extension cord suitable for outdoor use. Use of a cord suitable for outdoor use reduces the risk of electric shock.
- **IMPORTANT:** Make sure that the electric circuit is fused, and that the power, voltage and frequency of the motor is supported by your mains supply. Also, make sure that your power supply is earthed. Connect your machine to earth. Never open the ON/OFF switchbox. However, if it should become necessary to do so, contact a qualified electrician. Make sure that you will never touch live contacts, specifically when you plug or unplug your machine. This machine and its power cord must never get into contact with water.
- Avoid body contact with earthed or grounded surfaces such as pipes, radiators, ranges and refrigerators. There is an increased risk of electric shock if your body is earthed or grounded.
- To prevent electric shock, use only with an extension cord suitable for outdoor use. For additional protection, the installation of a residual current device (RCD) having a rated residual operating current not exceeding 30mA is advisable.
- Before use, check that the extension cord is in good condition. When using an extension cord, make sure to use one heavy enough to carry the current your product will draw. An undersized cord will cause a drop in line voltage resulting in loss of power and overheating.
- Do not allow any part of the machine to make contact with water while it is in operation. If the appliance becomes wet while turned off, wipe dry before starting. Do not touch the appliance or its plug with wet hands or while standing in water. Wearing rubber boots offers some protection.
- Before use, check the supply and extension cord for signs of damage or aging. If the cord becomes damaged during use, disconnect the cord from the supply immediately. If the supply cord is damaged, it must be replaced by the manufacturer or a qualified person in order to avoid a hazard.

Double-Insulated Appliances

In a double-insulated appliance, two systems of insulation are provided instead of grounding. No grounding means that it is already provided on a double-insulated appliance. Servicing a double-insulated appliance requires extreme care and knowledge of the system, and should be performed only by qualified service personnel. Replacement parts for a double-insulated appliance must be identical to the parts they replace.

Safety Information

Vibrations (Where Applicable)

- Prolonged use of hand held (operated) machines will cause the user to feel the effects of/from vibrations. These vibrations can lead to white finger (Raynaud's phenomenon) or carpal tunnel syndrome. This condition reduces the ability of the hand to feel and regulate temperature, causing numbness and heat sensations and may cause nerve damage and circulatory tissue death.
- Not all factors that lead to white finger disease are known, but cold weather, smoking and other diseases that affect blood vessels and blood circulation as well as large and long-lasting impact of shocks are considered factors in the formation of white finger. Note the following to reduce the risk of white finger and carpal tunnel syndrome;
- Wear gloves and keep your hands warm.
- Take regular breaks.
- All of the above precautions may help reduce the risk of white finger disease but not rule out the carpal tunnel syndrome. Long-term and regular users are therefore recommended to observe the condition of your hands and fingers. Seek medical attention immediately if any of the above symptoms should occur.

Noise (Where Applicable)

- The operating noise of the machine can damage your hearing. When wearing protection such as earplugs or ear defenders to protect your hearing. Long-term and regular users are advised to have hearing checked regularly. Be especially vigilant and cautious when wearing ear protection because your ability to hear alarm warnings will be reduced.
- Noise emissions for this equipment is unavoidable. Carry out noisy work at approved times and for certain periods. Limit the working time to a minimum. For your personal protection and protection of people working nearby it is also advisable for them to wear hearing protection.



- See Certificate of Conformity section for Outdoor Noise declaration of conformity.

Residual Risks

Even when tool is used as prescribed it is not possible to eliminate all residual risk factors. The following hazards may arise in connection with the tool's construction and design:

1. Damage to lungs if an effective dust mask is not worn.
2. Damage to hearing if effective hearing protection is not worn.

Health defects resulting from vibration emission if the power tool is being used over longer period of time or not adequately managed and properly maintained.

▲ WARNING! This machine produces an electromagnetic field during operation. This field may under some circumstances interfere with active or passive medical implants. To reduce the risk of serious or fatal injury, we recommend persons with medical implants to consult their physician and the medical implant manufacturer before operating this machine.

Safety Information

Intended Use

The HYSC1532E is a lawn scarifier and aerator from Hyundai, ideally suited for small to medium sized lawns. The HYSC1532E has a working width of 320mm and is powered by a 1500W motor.

The operator is able to operate the machine and use the main controls, always staying behind the handle at a safe distance from the rotating blade. If the operator leaves the machine, the motor and cutting means will stop within a few seconds.

The scarifier is manufactured according to the latest safety requirements. These include the OPC lever which stops the motor when you let go of the lever. Every precaution is only effective when it is followed exactly.

Intended Use

The basic version of the equipment is a scarifier intended for private use, i.e. for use in home and gardening environments. The scarifier is designed for ripping moss and weeds out of the soil and for loosening the soil. As a result your lawn can absorb nutrients better and is cleaned. We recommend you to scarify your lawn in the Spring and Autumn.

This machine is intended for use in environments with a maximum ambient temperature of 32°C.

User Types

This machine is intended for use by consumers, i.e. non professional operators. The machine is intended for “DIY” and domestic use only.

Improper Use

Any other usage not in keeping with the above mentioned ones may be hazardous and harm persons and/or damage things. Examples of improper use may include, but are not limited to:

- Transporting people, children or animals on the scarifier.
- Using the machine to tow or push loads.
- Using the machine for leaf or debris collection.
- Use of the machine by more than one person.
- Using the scarifier on surfaces other than grass.

Safety Information

Personal Protective Equipment

Appropriate Personal Protective Equipment (PPE), MUST be worn at all times when operating or repairing the machine. No protective equipment can ensure 100% protection.

When selecting PPE, make sure it's CE marked and it suits the user in terms of size, fit, etc. If more than one item of PPE is worn at the same time, make sure they can be used together, e.g. wearing safety glasses may disturb the seal of a respirator, causing air leaks.



Hand Protection Must Be Worn

Protective electrically non-conductive gloves are highly recommended when working.



Foot Protection Must Be Worn

Non-skid heavy duty footwear are highly recommended when working.



Hearing Protection Must Be Worn

Suitable safety hearing protection is recommended.



Eye Protection Must Be Worn

Always wear safety glasses/goggles and/or face shields. Everyday eyeglasses have only impact resistant lenses; they are not safety glasses/goggles.



Protective Clothing Must Be Worn

Do not wear loose clothing, gloves, scarfs, neckties or jewellery (rings, wrist watches), which can be caught in moving parts.



Head Protection Must Be Worn

Wear a safety helmet with a safety visor.

















Face Shield Must Be Worn

Wear a face shield to protect your face.

Safety Information

⚠ Symbols On The Machine







We have provided safety messages in this manual and on the machine. This information alerts you to potential hazards that could hurt you or others. Please read these messages carefully. However, we may not have listed all of the possible hazards, you must also use your own judgement.

Symbol	Description	Symbol	Description
	Safety alert – Indicates a precaution, a warning or a danger.		Danger! Electric shock risk.
	Do not expose to rain.		Class II tools symbol.
	Read operator's manual.		Keep bystanders at a safe distance away from the work area.
	Do not use the machine if the cable is damaged.		The UKCA (UK Conformity Assessed) marking is a UK product marking that is required for goods being placed on the market in Great Britain (England, Wales and Scotland).
	Danger! Rotating blades – keep hands and feet away from moving parts.		This product complies with the European directives and an evaluation method of conformity for these directives was done.
	Keep bystanders at a safe distance away from the work area.		Sharp blades can cut limbs.
	This product should not be disposed of in domestic waste. Please contact your local recycling centre for disposal service.		Switch off and unplug the device before cleaning or performing maintenance on it.

Safety Information

⚠ Symbols On The Machine (continued)

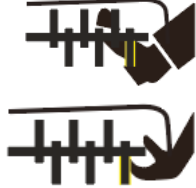
We have provided safety messages in this manual and on the machine. This information alerts you to potential hazards that could hurt you or others. Please read these messages carefully. However, we may not have listed all of the possible hazards, you must also use your own judgement.

Symbol	Description	Symbol	Description
	Hearing protection must be worn.		Danger! The blade can cut the cable.
	Eye protection must be worn.		Do not touch the rotating parts.
	Danger! Rotating blades – keep hands and feet away from moving parts.		Danger! Do not run over the cable.

Unboxing

⚠ WARNING : Unboxing and assembling the machine should be done on a flat, surface with enough room. Disposal of the packaging should be done in accordance with the local regulations in force.

⚠ WARNING : Some of the packaging material may be harmful to children. Keep out of reach of children.

1. Carefully remove the product from the packaging and examine it for any sign of damage caused during shipping.
2. Lay the contents out and check them. If any part is damaged or missing, you must not use the machine. Contact HYUNDAI POWER PRODUCTS immediately.
3. You must keep the packaging material in case the machine needs to be returned or repaired.
4. Ensure that you have all the accessories and tools you need for assembly and operation including the suitable personal protective equipment.

In The Box

*Not To Scale



Descriptions on next page 

In The Box

- A** Machine Body
- B** Switch Module and Power Cable
- C** Lower Handles
- D** Middle Handles
- E** Upper Handle
- F** Cable Strain Reliever
- G** 2 x Cable Clips
- H** 4 x Wing Nuts
- I** 4 x Bolts
- J** Collection Box
- K** Hex Key
- L** Scarifier Cartridges (One attached to machine)

Features



Descriptions on next page 

Features

- B Switch Module**
Contains the Safety Button and Trigger.
- F Cable Strain Reliever**
Prevents damage to cable during operation.
- G Cable Clips**
Secures the cable.
- H Wing Nut and Bolt**
Used to secure the handles together.
- J Collection Box**
Collects waste when operating.
- M Safety Button**
Prevents the Machine being accidentally turned on.
- N On/Off Trigger**
Starts and stops the machine.
- O Height Adjustment Lever**
Changes the operation height.
- P Power Cable**
Provides power to the machine.

Assembly

STEP 1 : Lower Handles

1. Remove the screws in the machine body.

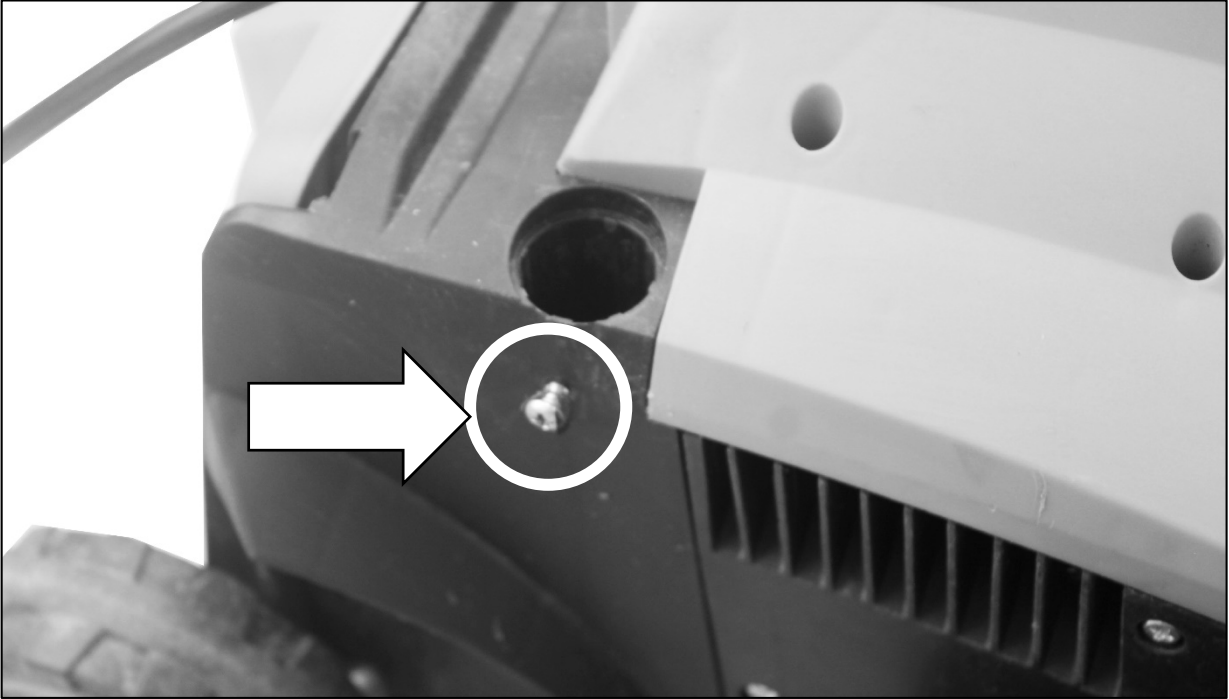

2. Insert the lower handle into the slot of the machine body.



Continued on next page 

Assembly

STEP 1 : Lower Handles (continued)

3. Tighten the screw into the machine body to secure the lower handles. Repeat on both sides.



! If the screw doesn't secure the lower handle, ensure you have it the right way around, with the small hole facing outward.

Continued on next page 

Assembly

STEP 1 : Lower Handles (continued)

4. Secure a middle handle to a lower handle using the bolt and hand nut. Place a bolt through the lower and middle handles, then tighten on a hand nut. Repeat this on both sides.



Assembly

STEP 2 : Upper Handle & Switch Module

1. Put the strain-reliever around the upper handle.



2. Attach the upper handle, to the middle handle, secure with bolts and wing nuts—refer to **PAGE 22**.



Continued on next page 

Assembly

STEP 2 : Upper Handle & Switch Module (continued)

3. Remove the screws from the rear of the switch module, and separate it from the mating part.
4. Mount the switch module to the upper handle as shown. Ensure the safety button is facing upward.
5. From the other side secure the switch module to the mating part with the screws.



STEP 3 : Cable Management

Cable Strain Reliever

1. Create a loop with the cable and pass it through the Strain Reliever.
2. Pass the cable over the hook and gently pull the cable to secure.

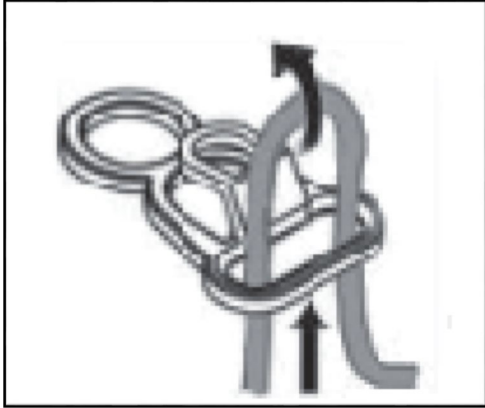

Cable Clips

1. Place the larger side of the clip around the bars.
2. You can now place the power cable in smaller side of the clip.



Assembly

STEP 4 : Collection Box Assembly

1. Pull the collection box mesh over the frame. Secure the longest clips (top and bottom) to the rails of the frame.
2. Secure the 3 smaller clips to the side rails of the frame, make sure this is done on both sides.
3. The collection box is now ready to be attached to the machine body.

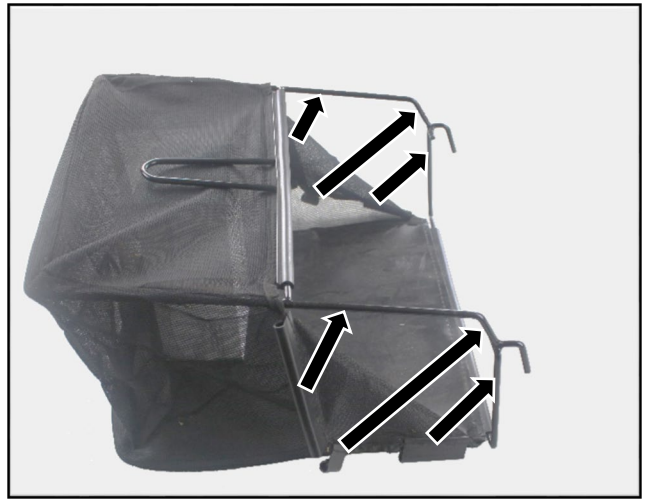
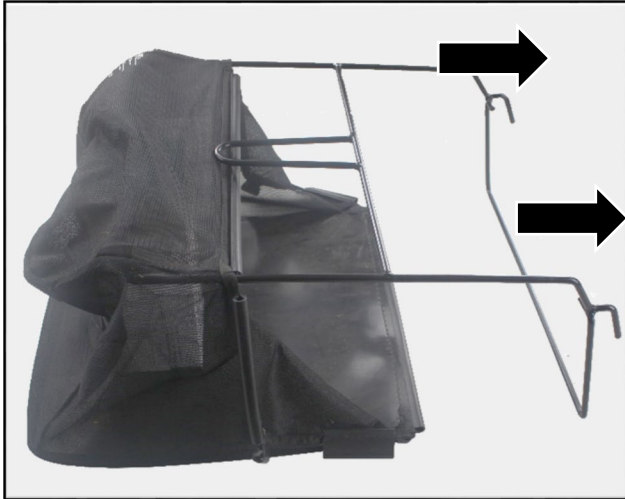

Assembly

STEP 5 : Attaching Collection Box

1. Lift the rear discharge flap and locate the collection box tabs.



2. Hook the collection box on to the tabs and allow the discharge flap to rest on top.



Continued on next page 

Assembly

STEP 5 : Attaching Collection Box (continued)

3. The HYSC1532E is now ready to be used.



Tips & Tricks – Understanding Scarification

What is Scarification?

Scarification is the process of removing “Thatch” and other organic garden matter from the base layer of your lawn. Thatch is build up of moss, lawn clippings and small weeds , that suffocate a lawn from oxygen and retain water.

Benefits of Scarifying

- Prunes Grass roots encouraging growth
- Create better flow of oxygen
- Reduce water logging and water retention
- Allows water and nutrients to reach the roots of the lawn.

Scarifying - Rigid Steel Blade Cartridge

The steel blades are specially designed to remove all unnecessary organic matter from a lawn. These blades penetrate the ground ensuring the lawn absorbs nutrients better

Raking /Aerating- Spring Tine Cartridge

The rake cartridge is designed to lightly scratch the surface of the ground. This will improve the water drainage and aid oxygen absorption by removing

When to Scarify

It's best to scarify a lawn when it has time to recover. In the Autumn or Spring months is a good time. In these seasons the lawn will see a good amount of moisture and sunshine.

Your lawn will take around 4-6 weeks to recover after being scarified (weather dependant).

DO NOT scarify a lawn in the summer or winter months. The ground will not be able to support a full recovery.

Tips & Tricks – Scarifying & Raking

Lawn Preparation

Before scarification, always ensure the grass is cut to a length of around 40mm. This will prevent the machine from pulling out healthy grass when extracting thatch.

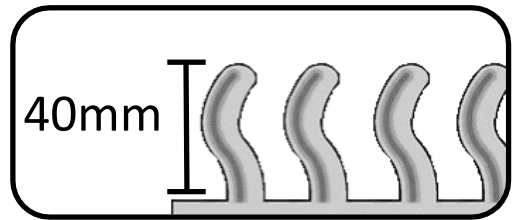

Post Scarification Treatment

After scarifying a lawn, use fertilizer and grass seed to help the lawn recover. The lawn will have the tools it needs to become healthier.

Scarifier Cartridge (Rigid Steel Blades)

This cartridge is designed to break the built up thatch, and penetrate the ground. This helps the lawn breathe, allow oxygen and water reach the roots.

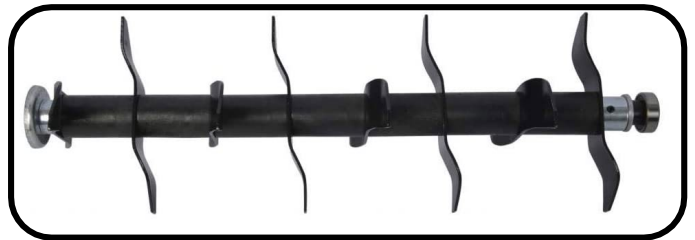

Lawn Raking

Raking a lawn extracts the Thatch without penetrating the ground. This can be seen as a less aggressive method used to maintain a healthy lawn. You should not rake grass longer than 75mm

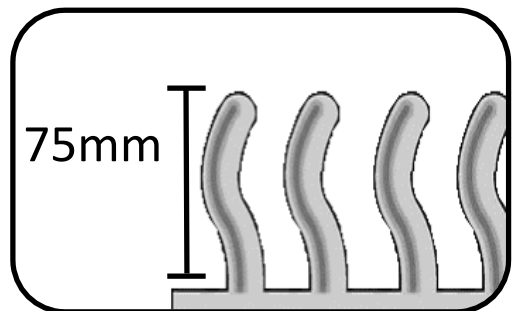

Rake Cartridge (Spring Tine Cassette)

The Spring Tine Cassette Cartridge is design to scratch at the ground of the lawn without penetration. This will extract the unwanted thatch and small weeds.

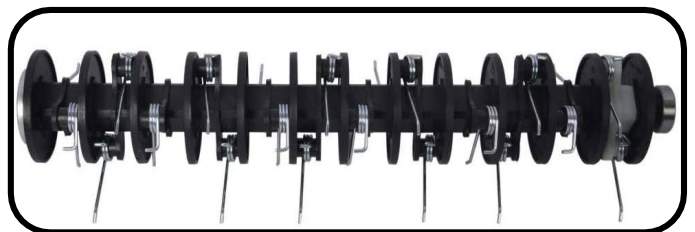

Operation

Height Adjustment

! When adjusting the machine height, ensure you set the correct height for the cartridge.

1. To adjust the height of the HYSC1532E, firstly you need to pull the lever up.
2. Then you pull the lever into your preferred height.

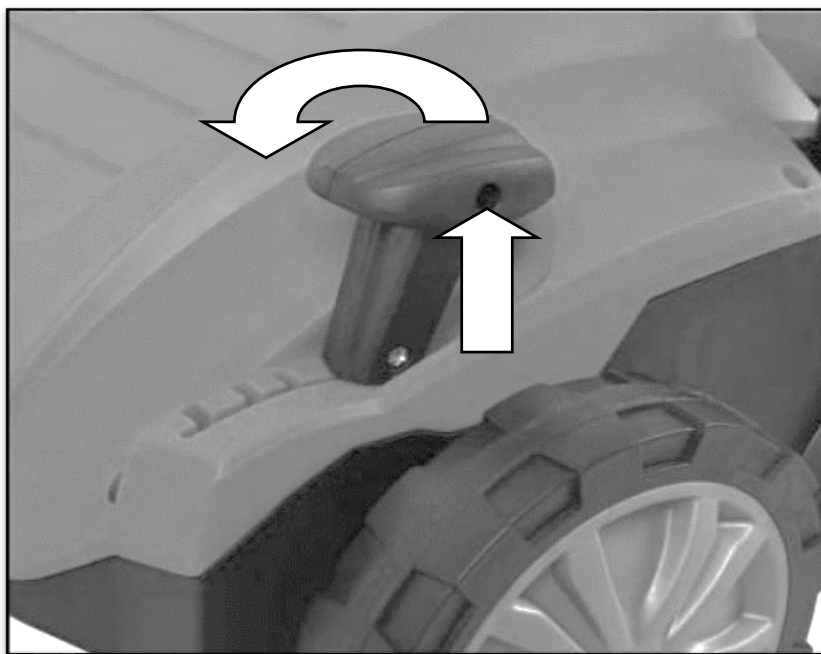

Height Settings

Position	Scarifier Cartridge	Rake Cartridge
1	-12mm	-3mm (not recommended to use rake at this height)
2	-8mm	1mm
3	-4mm	5mm
4	4	13mm

! It is not advised to use the Rake on position 1, as this can be too aggressive for unhealthy grass.

Operation

Starting & Stopping

! Ensure before starting your HYSC1532E, the machine is plugged into a power source, with the switch on.

Starting

1. To start the machine, you must first press the Power Safety Button **(M)**. The machine WILL NOT start if this isn't pressed.
2. Whilst holding down the Power Safety Button **(M)** pull the Power Lever **(N)**. When pulling the Power Lever **(N)** the machine will start.
3. The Power Safety Button **(M)** can be released when the machine turns on.

Stopping

1. To stop the machine, simply release the Power Lever **(N)**.
2. Switch off the power source and unplug the machine.

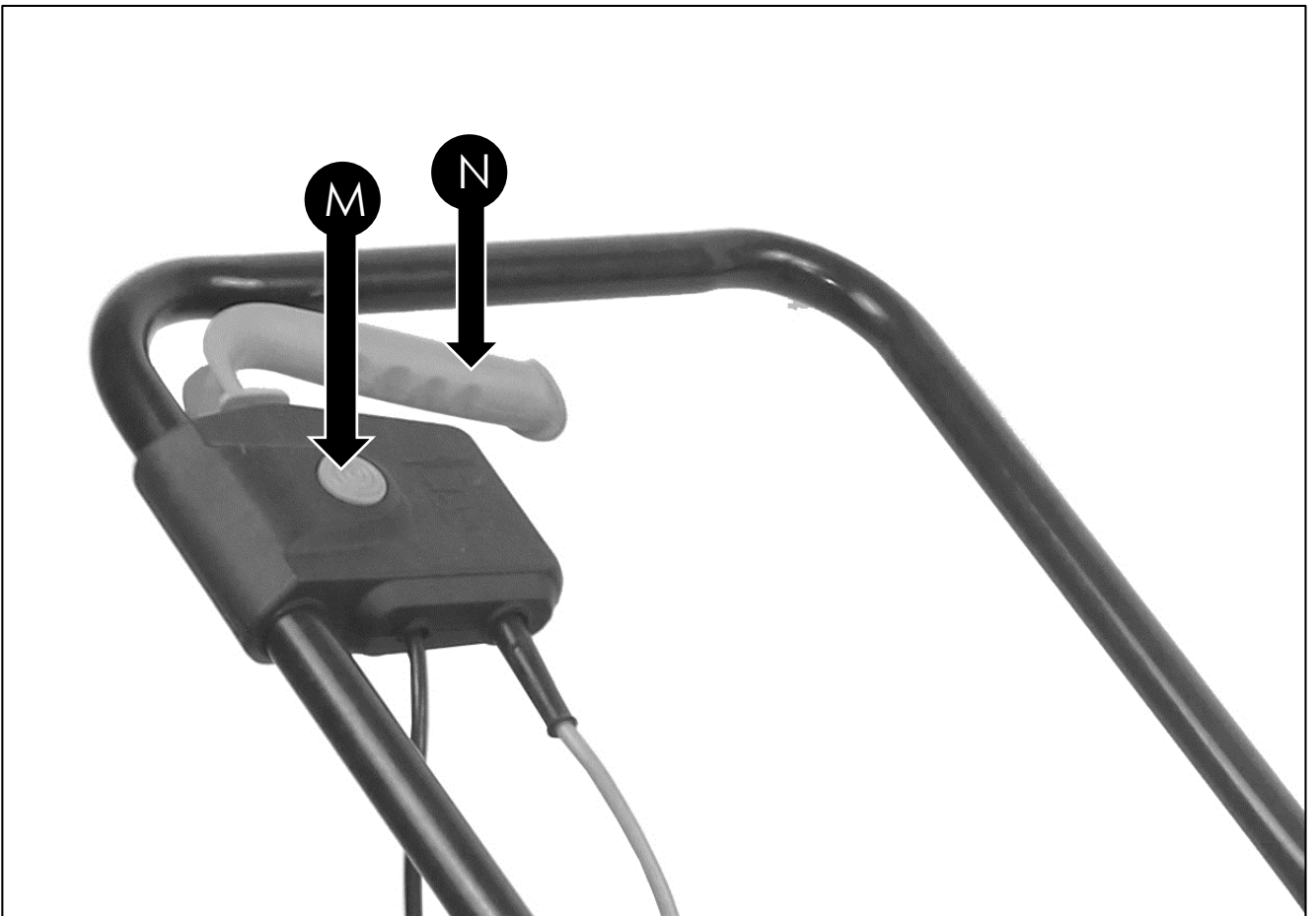

Maintenance & Care

Changing The Cartridge

⚠ WARNING : When changing the Cartridge the machine **MUST NOT** be plugged into a power source.

1. Remove the bolts on the Cartridge clamp (**Q**) using the included Hex Key.
2. Lift the cartridge whilst pulling out away from the spindle (**R**).
3. To replace cartridge, follow the previous step in reverse.

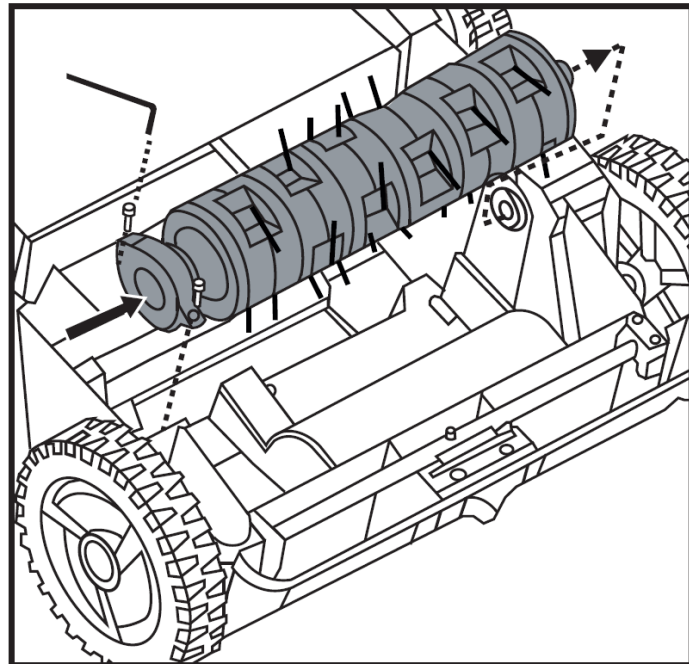
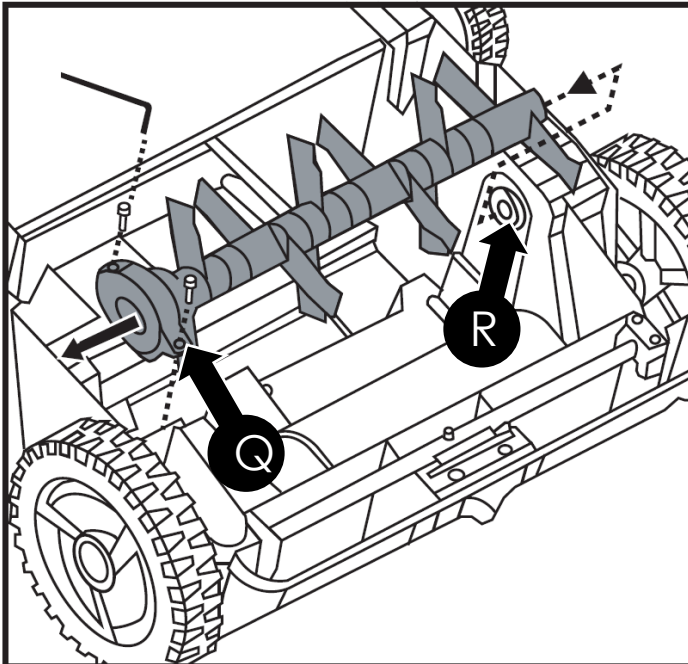

Maintenance & Care

General Maintenance

⚠ WARNING : Turn OFF the machine, allow all moving parts to come to a complete stop, and disconnect the power cord before maintaining the machine. You need to wear proper clothing and protective gloves whenever your hands are at risk.

- Keep all nuts, bolts and screws tight to be sure the machine is in a safe working condition.
- Replace worn or damaged parts for safety. Only use manufacturer-recommended parts and accessories.
- To keep your machine in good working condition, you can use spray lubricating oil along the blade, on the top of the blade, and the bottom of the blade.

Transportation

Whenever the machine is to be handled, lifted, transported or tilted, you must:

1. Wear sturdy work gloves.
2. Hold the machine at the points that offer a safe grip.
3. Use an appropriate number of people for the weight of the machine and the characteristics of the vehicle or the place where it must be placed or collected.
4. During transport, make sure to fasten the machine securely with cables or straps.
5. The machine must be transported on a flat surface.

Storage

⚠ Keep the machine stored in a dry, level area away from damp, moisture and rain fall. Allow the machine to cool down before storing.

- Make sure the machine is clean and dry before storing.
- Make sure the machine is stored away from direct sunlight. Store indoors or in a safe, locked protected area during severe weather and winter months.
- Ensure the machine is stored in a position, where any persons cannot step on to attempt to reach items up high, due to risk of movement.
- DO NOT store the machine near an ignition source, such as a wood stove, gas or electric heater, or an appliance or heater with a pilot light.
- Store the machine out of reach of children or anyone who is not familiar with operation.
- DO NOT stack other items on top of the machine when in storage.

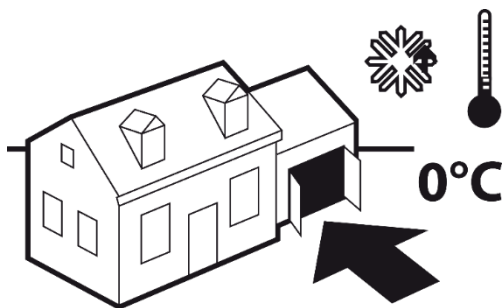

Maintenance & Care

Cleaning

⚠ Always remove the electric plug from the mains supply before any cleaning is undertaken.

- Remove any grass and mud after each use to prevent it from drying. Use a clean cloth to remove dirt, grease, etc.
- DO NOT use any water on any part of the main machine.
- Avoid using solvents when cleaning plastic parts. Most plastics are susceptible to damage from various types of commercial solvents and may be damaged by their use.
- Always ensure that ventilation openings are kept clear of debris.

The Blade

⚠ WARNING!

- Never touch a rotating blade.
- The blade should always be sharp and well balanced. At regular intervals, check the tightness of all nuts, bolts and screws.
- If the blade hits an obstacle, check for damage and if the machine vibrates badly, stop the machine and take it to a service dealer.
- It is best if all interventions on the blade are done at a specialised centre that has the special tools and equipment.

POWER SPARES



No Hassle Returns



Same Day Dispatch*



Over 10,000 Spare Parts



QR Code – Scan the QR code for a direct link to our website

Our Website : power-spares.co.uk

Call us : 01646 404406

Email us : sales@power-spares.co.uk

To maintain your machine in peak operating condition, proper maintenance and care are crucial. Some machines have consumable parts that will need replacement to ensure they continue operating at their full potential. Power-Spares provide manufacturer parts for all your machines, ensuring they remain in peak condition.

About Power Spares

Power-Spares has your back if you damage your lawn mower blade, find your spark plugs not sparking, or snap your recoil. Power-Spares operates under the trading name of Genpower Limited.

As part of the Genpower family, Power-Spares offers you the expertise, efficiency, and quality assurance of a large organisation. We leverage the latest warehousing, distribution, customer service, and inventory management technology to ensure you receive your parts as quickly as possible.

With extensive stock-holding of spare parts in our UK warehouses, Power-Spares is ready to assist you promptly when your machine needs repair. We're Committed to help you get back up and running as quickly as possible.

Maintenance & Care

Spare Parts

⚠ Only use original spare parts: The use of non-original and/or incorrectly fitted parts will jeopardise the safety of the machine, may cause accidents or injuries for which the manufacturer is under no circumstance liable or responsible.

- 1 Find the part you are looking for in the drawings.
- 2 Information about the parts can be found in the tables below or visit power-spares.co.uk
- 3 Use this information to order the part.
- 4 Contact us if you need help finding the correct part.

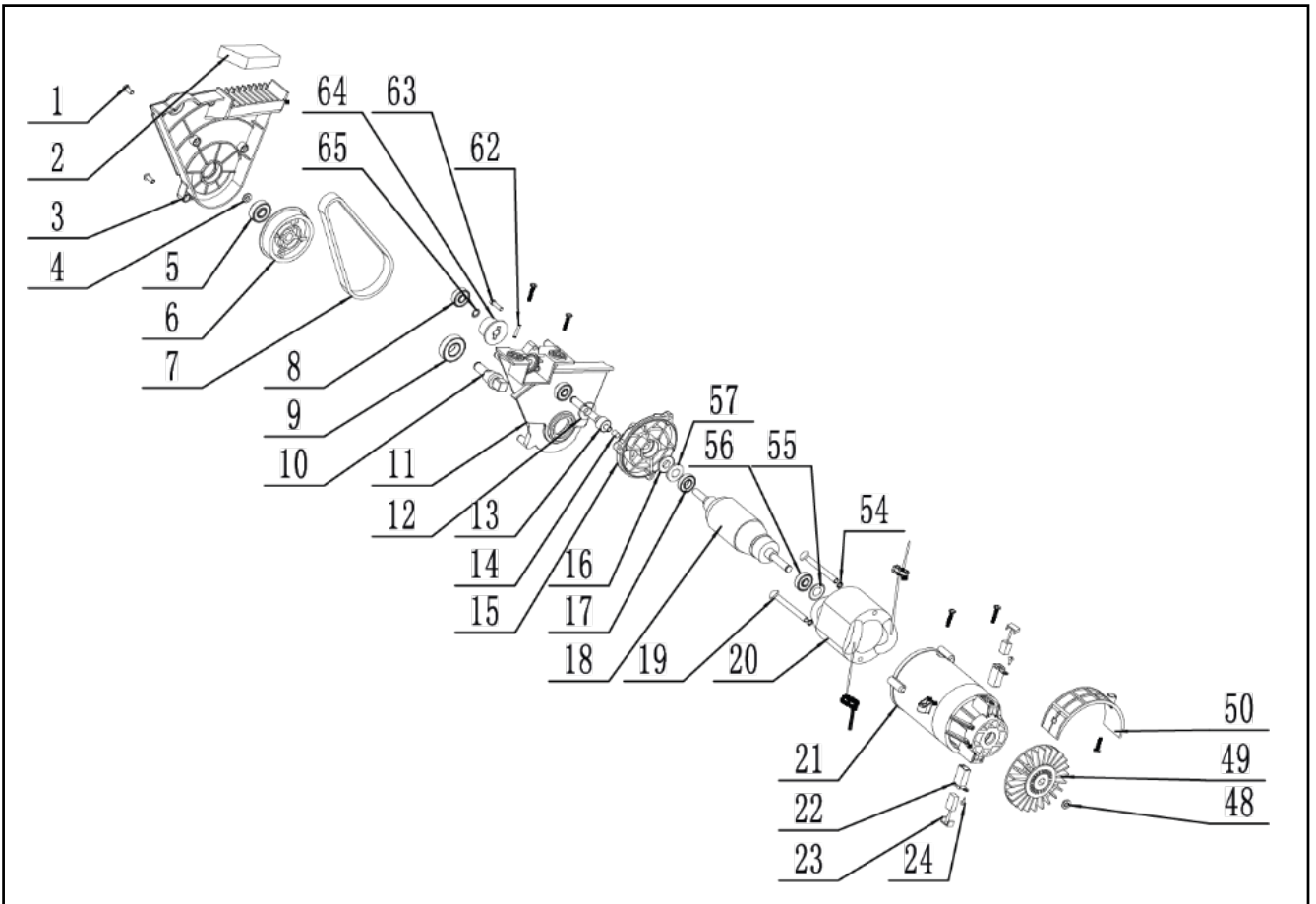

Maintenance & Care

Spare Parts

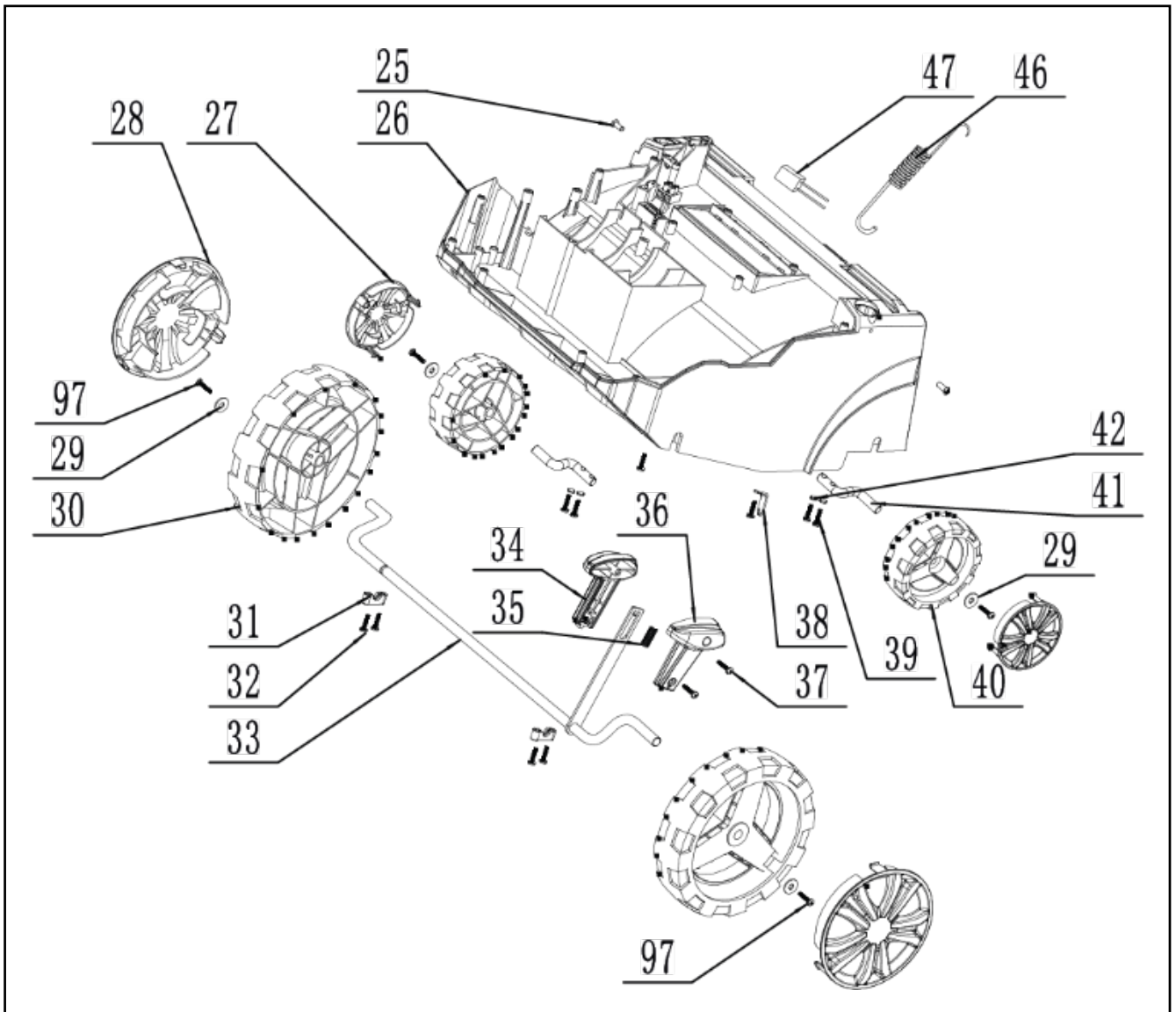

Maintenance & Care

Spare Parts

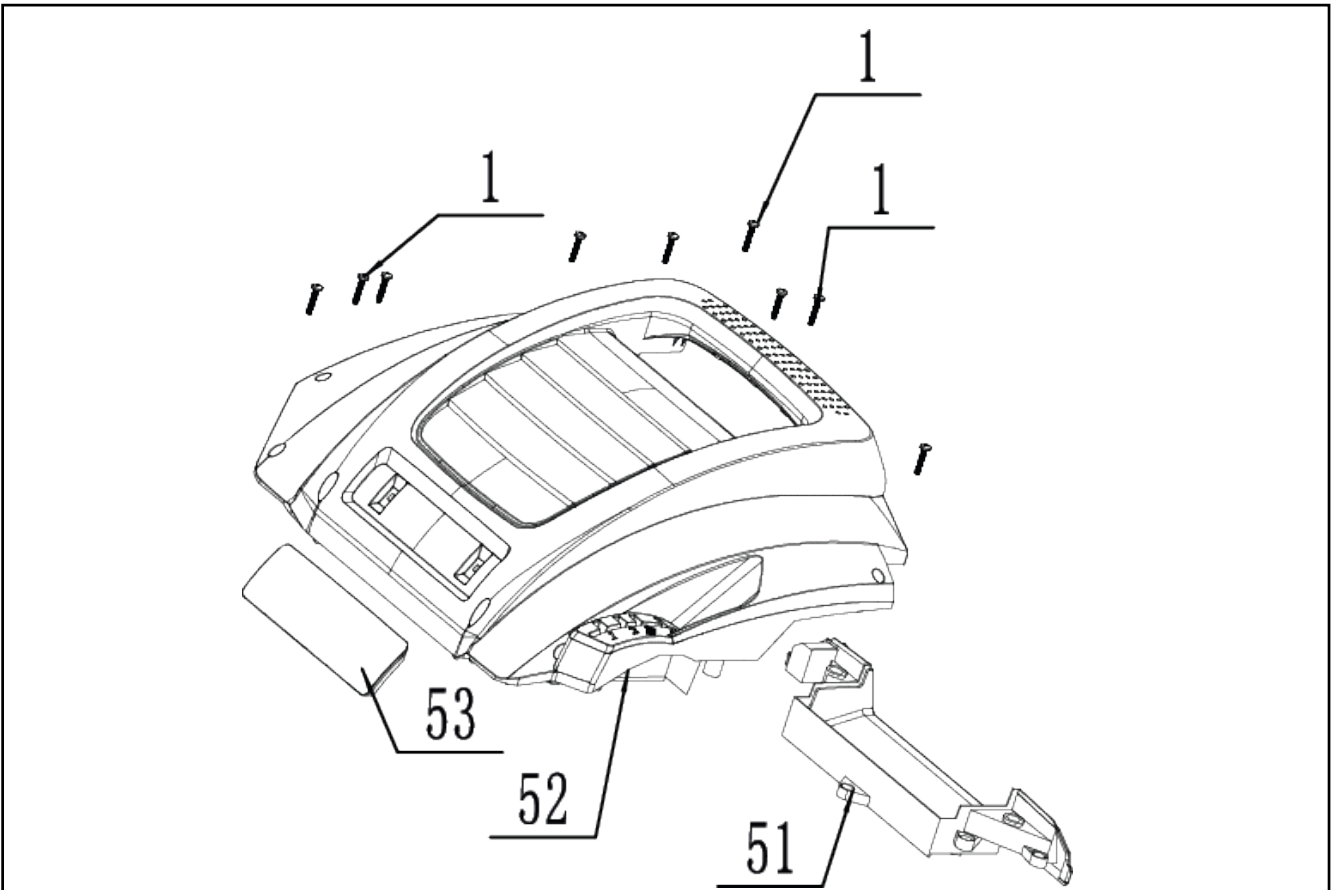
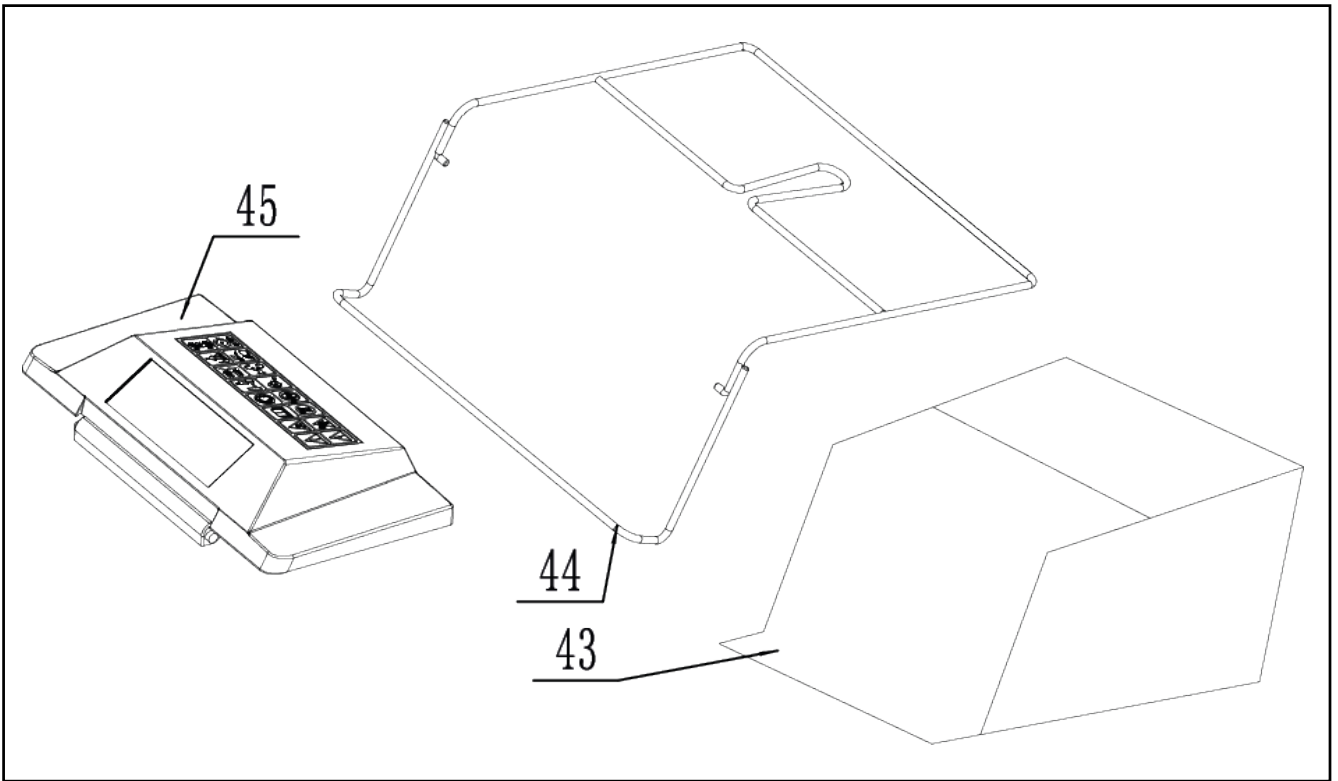

Maintenance & Care

Spare Parts

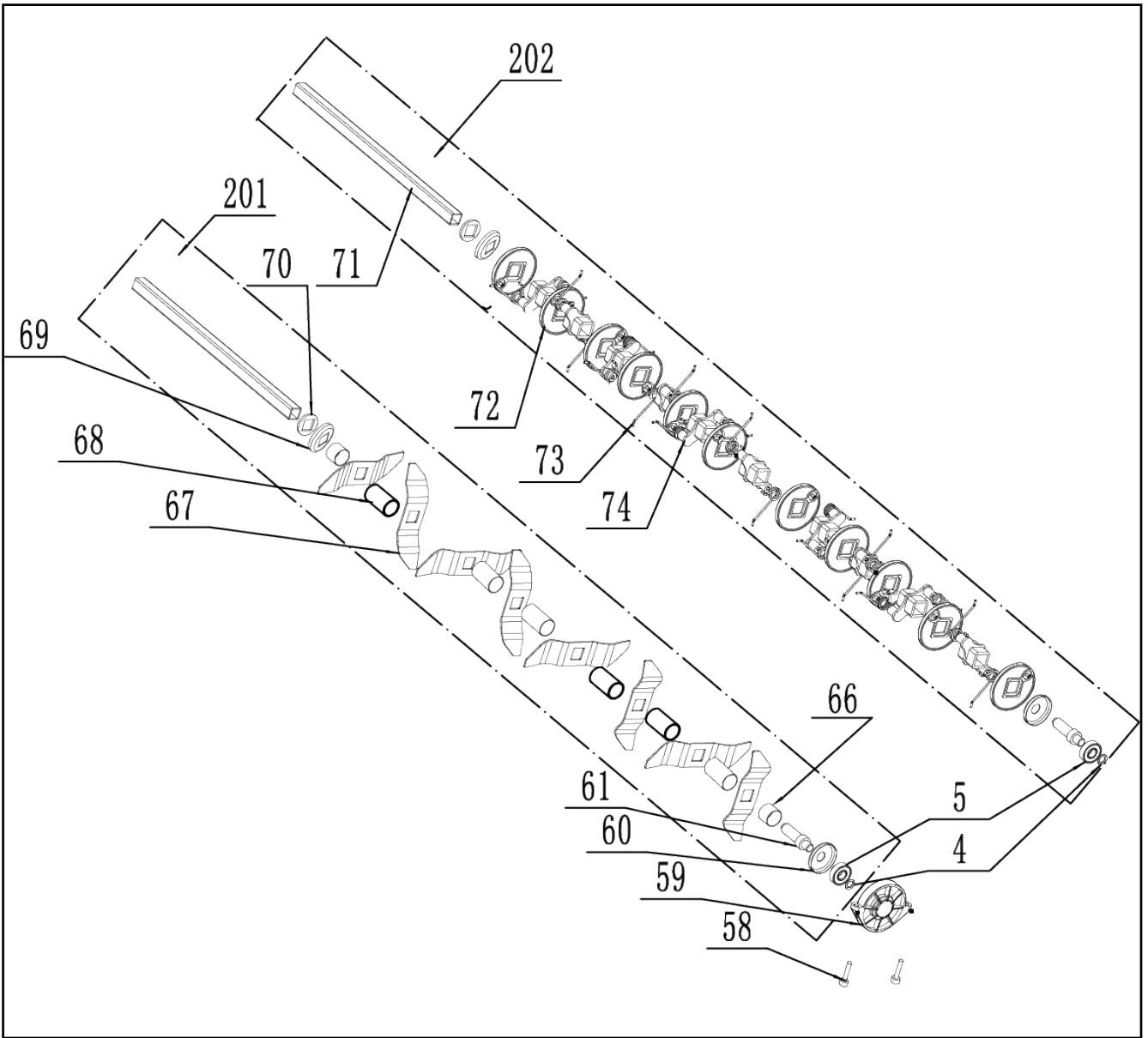

Maintenance & Care

Spare Parts

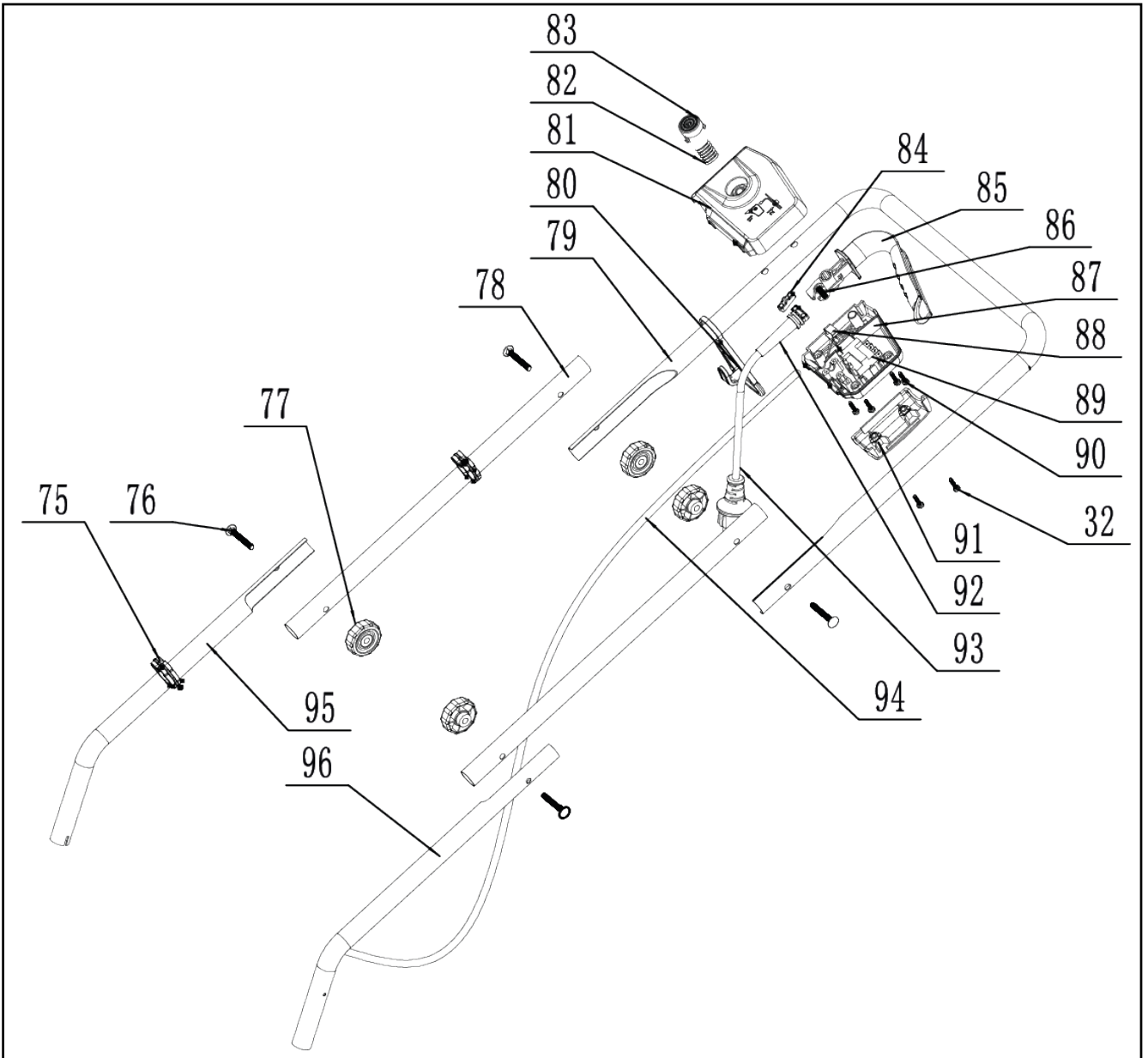

Maintenance & Care

Spare Parts

Drawing Number	Spare Part Name	Part Number
1	Screw ST4X20	1354001
2	Filter Sponge	1354002
3	Cover of Belt Wheel	1354003
4	Axle Check Ring	1354004
5	Bearing 6000	1354005
6	Belt Wheel	1354006
7	Belt	1354007
8	Bearing 608	1354008
9	Bearing 6002	1354009
10	Belt Wheel Axle	1354010
11	Belt Wheel Support	1354011
12	Red Steel Paper Washer	1354012
13	Output Axle	1354013
14	Needle Roller Bearing	1354014
15	Gear Box	1354015
16	Wool Felt	1354016
17	Bearing 6900	1354017
18	Rotor Kit	1354018
19	Self-tap Screw	1354019
20	Stator Kit	1354020
21	Motor Cover	1354021
22	Carbon Brush Frame	1354022
23	Carbon Brush	1354023
24	Self-tap Screw	1354024
25	Self-tap Screw	1354025
26	Housing	1354026
27	Wheel Cover 100MM	1354027
28	Wheel Cover 180MM	1354028
29	Gasket 5mm	1354029
30	Front Wheel	1354030
31	Front Axle Clamp	1354031
32	Self-tap Screw	1354032
33	Front Wheel Bracket	1354033
34	Left Shift	1354034
35	Shift Spring	1354035
36	Right Shift	1354036
37	Self-tap Screw	1354037
38	Tension Spring Fixed Plate	1354038
39	Self-tap Screw	1354039
40	Rear Wheel	1354040
41	Rear Wheel Fixed Axis	1354041

Maintenance & Care

Spare Parts

Drawing Number	Spare Part Name	Part Number
42	Elastic Gasket 5MM	1354042
43	Clippings Bag	1354043
44	Trash Bin	1354044
45	Trash Bin Clamp	1354045
46	Trash Bin Clamp Spring	1354046
47	Therminal Switch	1354047
48	Axle Check Ring	1354048
49	Motor Fan	1354049
50	Duct Cover	1354050
51	Chassis Plate	1354051
52	Housing	1354052
53	Logo Cover	1354053
54	Elastic Gasket 4MM	1354054
55	Wave Washer	1354055
56	Bearing 608	1354056
57	Baize 10MM	1354057
58	Screw M5X16	1354058
59	Bearing Base	1354059
60	Dust-proof Cushion (Round Hole)	1354060
61	Connecting Axle	1354061
62	Belt Wheel Axle	1354062
63	Screw	1354063
64	Belt Wheel	1354064
65	Bearing Pads	1354065
66	Blade Separate Sleeve	1354066
67	Blade	1354067
68	Blade Separate Sleeve	1354068
69	Dust-proof Cushion (Square hole)	1354069
70	Square Axle Protection Washer	1354070
71	Square Axle	1354071
72	Holder Cover	1354072
73	Pawl Spring Holder	1354073
74	Pawl Spring	1354074
75	Cable Clip	1354075
76	Screw M6X45	1354076
77	Hand Bar Knob	1354077
78	No2 Lift	1354078

Maintenance & Care

Spare Parts

Drawing Number	Spare Part Name	Part Number
79	No 3 Lift	1354079
80	Cable Clip	1354080
81	Switch Box Right	1354081
82	Switch Button Spring	1354082
83	Switch Button	1354083
84	Cable Clamp	1354084
85	Switch Lever	1354085
86	Switch Lever Spring	1354086
87	Switch Box Left	1354087
88	Switch Box Rod	1354088
89	Switch	1354089
90	Self-tap Screw	1354090
91	Switch Box Clamp	1354091
92	Cable Sleeve	1354092
93	2/C Plug	1354093
94	2/C Cable	1354094
95	No 1 Lift Right	1354095
96	No 1 Lift Left	1354096
97	Screw M5*14	1354097
201	Blade Assembly - Soil	1354099
202	Blade Assembly - Grass	1354100

Technical Data

Specification

Model	HYSC1532E
Voltage	230V
Frequency	50Hz
Rated Power	1500W
No Load Speed	3000rpm
Working Width	32cm
Working Depth	-12mm to +4mm
Grass Collector Capacity	30L
Plug	British Standard
Cord Length	10M
Net Weight	9.8kg
Guaranteed Sound (Lwa)	98dB
HAV Vibration	4.246m/s ²
Uncertainty (K)	K=1.5m/s ²

Recycling & Disposal

Recycling & Disposal

We do not offer a takeback scheme for the recovery of Waste Electrical Electronic Equipment (WEEE) & Batteries. Instead the responsibility to dispose of WEEE and/or Batteries is passed onto you by us.

So when it becomes necessary to dispose of your machine you must take it to your local Civic Amenity Site. For further information please contact your local Authority for disposal advice.

You **MUST** make sure that all unused oil and fuel is disposed of correctly either beforehand or at your local Civic Amenity Site.

- Under NO circumstances must any fuel or oil be put down any drains.
- Certain products contain WEEE waste which should not be disposed of in your domestic waste.
- You **MUST** recycle WEEE in accordance with your local authority or recycling centre.
- Certain products contain batteries which should not be disposed of in your domestic waste.
- You **MUST** recycle batteries in accordance with your local authority or recycling centre.
- Unwanted packaging and materials should be stored and taken to a recycling centre so it can be disposed of in a manner which is compatible with the environment.

We are a Member of the VALPAK National Compliance Scheme and our registration number is RM08660. For further information about disposal please contact your Local Authority.

You can also get more advice and guidance about recycling at the following website <http://www.recycle-more.co.uk>

Should you pass this product on to another user either sold or loaned, you **MUST** pass on this user manual. This will make sure that all other users can use and maintain this machine safely.

Environmental Protection

1. Environmental protection should be a priority of considerable importance when using the machine, for the benefit of both social coexistence and the environment in which we live. Try not to cause any disturbance to the surrounding area.
2. You must comply with local regulations and provisions for the disposal of packaging, oils, fuel, filters, damaged parts or any elements which have a strong impact on the environment. This waste must not be disposed of as normal waste. It needs to be separated and taken to specified waste disposal centres where the material will be recycled.
3. You must comply with local regulations for the disposal of waste materials after mowing.
4. When disposing, do not pollute the environment with the machine, but hand it over to a disposal centre, in accordance with the local laws in force.

Declaration Of Conformity

Importer and Authorised Representative

Genpower Ltd
Isaac Way, Pembroke Dock, SA72 4RW
Country of Origin: China
Description: Electric Corded Scarifier
SKU Code: HYSC1532E
Date of Issue: 14/07/2021

Regulations and Directives of Compliance

- **2006/42/EC** - The Machine Directive
- **2014/30/EU** – harmonisation of the laws of the Member States relating to electromagnetic compatibility
- **2004/108/EC**
- **IEC 62841-1** - Electric Motor-Operated Hand-Held Tools Transportable Tools and Lawn and Garden Machinery – Safety

REFERENCES TO THE RELEVANT HARMONISED SAFETY STANDARDS USED OR REFERENCES TO THE OTHER TECHNICAL SPECIFICATIONS IN RELATION TO WHICH CONFORMITY IS DECLARED:

- EN 60335-1:2012+A11+A13+A1+A14+A2+A15
- EN 62233:2008
- EN 50636-2-92 : 2014
- EN IEC 55014-1:2021
- EN IEC 55014-2:2021
- EN IEC 61000-3-2:2019+A1
- EN 61000-3-3:2013+A1+A2

Statement of Declaration

We the importer and authorised representative of the product described confirm conformity within the provisions of applicable regulations and directives listed within this document.

Signed on Behalf of Genpower Ltd

Place of Issue: Genpower Ltd
Signatory Name: Roland Llewellyn
Position: Manaaina Director

R J Llewellyn
.....



Useful Information

Check Out Our YouTube Channel

Our videos on YouTube include:

- Unboxing
- Assembly of your machine
- How to service your machine
- Products in use
- 'How To' videos
- Product features

Go to YouTube and search '**Hyundai Power Products**'.

Warranty

Proof of purchase will be required before you make a warranty claim. Full warranty terms and conditions can be found on the HYUNDAI POWER PRODUCTS website:
www.hyundaipowerproducts.co.uk

Manual Updates

Our manuals are constantly being reviewed and updated. Should you find an error, omission or something unclear, please contact us for assistance. We reserve the right to make any modifications without prior notice whenever necessary. Our latest manuals are also placed online. All our manuals can be downloaded at:
www.hyundaipowerproducts.co.uk

Returning Your Product

If you are returning your product, please contact the dealer for their returns policy.

Leaving A Review

We work very hard to give all of our customers the best possible service. If you have any problems, before leaving negative feedback, please contact us to give us a chance to resolve the issue. We would be delighted if you left us positive feedback! To leave a review, please go to:
uk.trustpilot.com/review/hyundaipowerequipment.co.uk

Ordering Spare Parts

You can find the spare part you are looking for at **power-spares.co.uk**

Product Record

Information

As soon as you have purchased the machine, we recommend that you fill out the following. If you need to contact an authorised dealer or customer service for information on servicing, you may need to provide the following information.

Date Of Purchase:.....

Dealer Name:.....

Dealer Phone:.....

Model Number:.....

Serial / Batch Number:.....

Contact Us

Need Help? Talk To Our Experts

Our friendly aftersales team will be more than happy to help you.



Phone

Call our team on 01646 687 880



Email

aftersales@hyundaipowerproducts.co.uk



Online Live Chat

Go to www.hyundaipowerproducts.co.uk



Post

Genpower Ltd, Isaac Way, Pembroke Dock, Pembrokeshire, SA72 4RW.



Hyundai Support Website

Go to hyundaisupport.co.uk

HYUNDAI

POWER PRODUCTS



GENUINE PRODUCT OF
HYUNDAI CORPORATION

For Inquiries, Please Contact:
GENPOWER LTD
Isaac Way, London Road,
Pembroke Dock, UK, SA72 4RW.
T: +44 (0) 1646 687 880
E: info@hyundaipowerproducts.co.uk
www.hyundaipowerproducts.co.uk